

13.Crank Pulley

A: REMOVAL

NOTE:

When replacing a single part, perform the work with the engine assembly installed to body.

1) Remove the V-belts. <Ref. to ME(STI)-41, REMOVAL, V-belt.>

2) Use the ST to lock the crank pulley, and remove the crank pulley bolt.

ST 499977100 CRANK PULLEY WRENCH

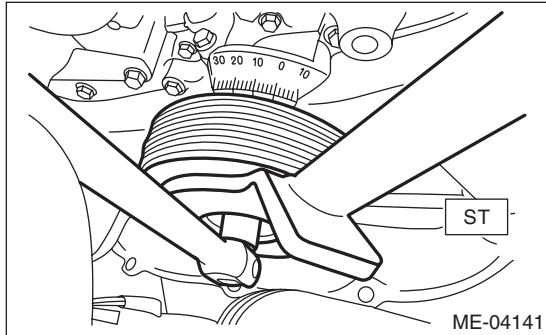

3) Remove the crank pulley.

B: INSTALLATION

1) Clean the crankshaft thread using compressed air.

2) Install the crank pulley.

3) Apply engine oil to the crank pulley bolt seat and thread.

4) Tighten the crank pulley bolts.

(1) Use the ST to lock the crank pulley, and temporarily tighten the crank pulley bolt.

ST 499977100 CRANK PULLEY WRENCH

Tightening torque:

47 N·m (4.8 kgf·m, 34.7 ft·lb)

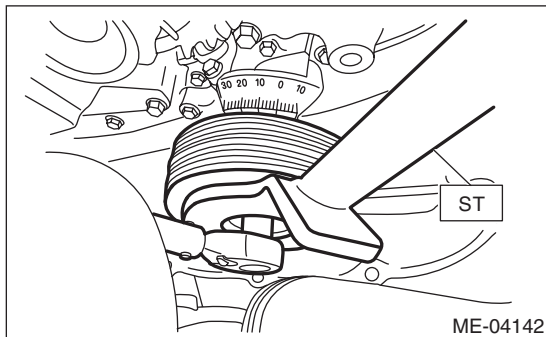

(2) Draw reference lines (A) and (B) using a marker to set the socket to the crank pulley bolt as shown in the figure.

NOTE:

Set the socket onto the crank pulley bolt so that reference lines (A) and (B) is visible.

ST 499977100 CRANK PULLEY WRENCH

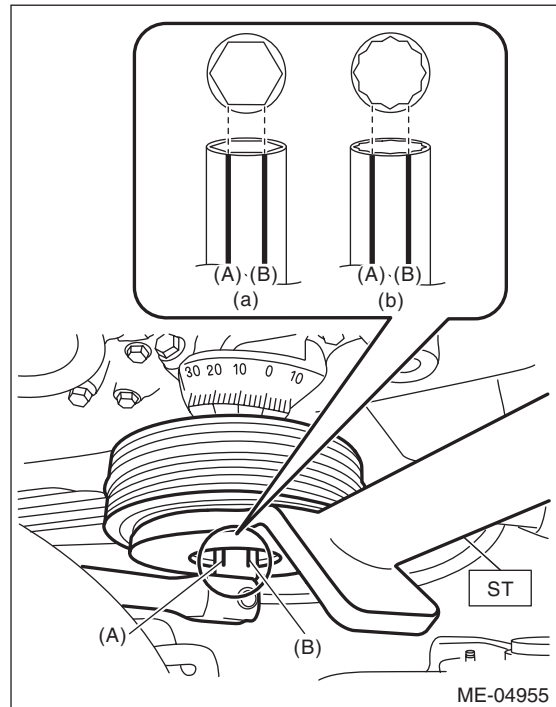

(a) When using 6-point socket

(b) When using 12-point socket

(3) Draw end line (C) on ST using a marker at the same position as reference line (B) drawn on the socket in step (2).

ST 499977100 CRANK PULLEY WRENCH

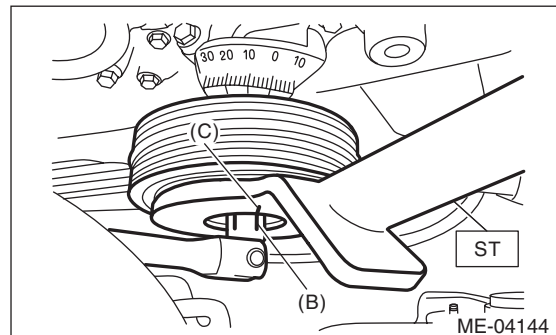

(4) Use the ST to lock the crank pulley, and tighten the crank pulley bolt to the angle where reference line (A) and end line (C) are aligned.

NOTE:

It should be approx. 60° when reference line (A) and end line (C) are aligned.

ST 499977100 CRANK PULLEY WRENCH

Tightening angle:

60°±5°

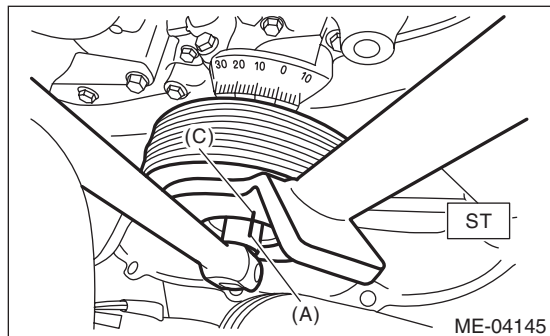

5) Install the V-belts. <Ref. to ME(STI)-41, INSTALLATION, V-belt.>

C: INSPECTION

1) Check that the crank pulley has no deformation, cracks or other damages.